

UC Irvine Autonomous Boat Project

Project Advisor: Professor Reinkensmeyer



UCI Samueli
School of Engineering

BACKGROUND

- The MicroTransat challenge encourages teams to cross the Atlantic ocean autonomously.
- As of today, no one has done it successfully.
- Autonomy is an important part of everyday life.



INNOVATION & DESIGN

- Diesel Electric Cogeneration
 - Thermoelectric couplers.
 - High Efficiency, lower CO2 emissions.
- Autonomous Software
- Links between software and hardware.
 - Sensors on engine giving feedback to computer.

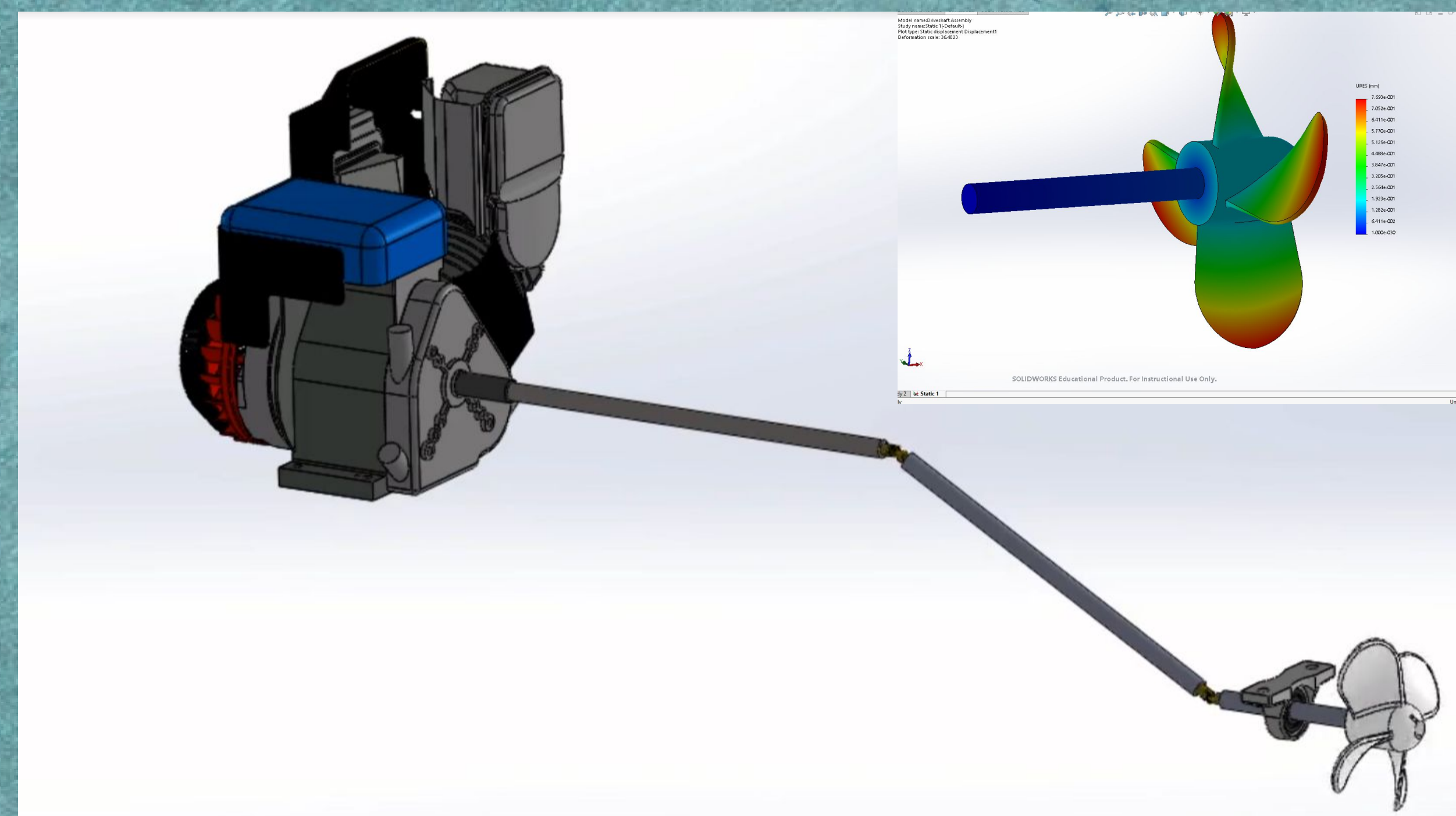

GOALS & OBJECTIVE

- Design and construct an autonomous boat to cross Atlantic Ocean.
- Compete In the MicroTransat Challenge.
- Autonomy can pave the way for systems that can deliver medical supplies and humanitarian aid.
- Be the first team to complete this feat.
 - Innovative design

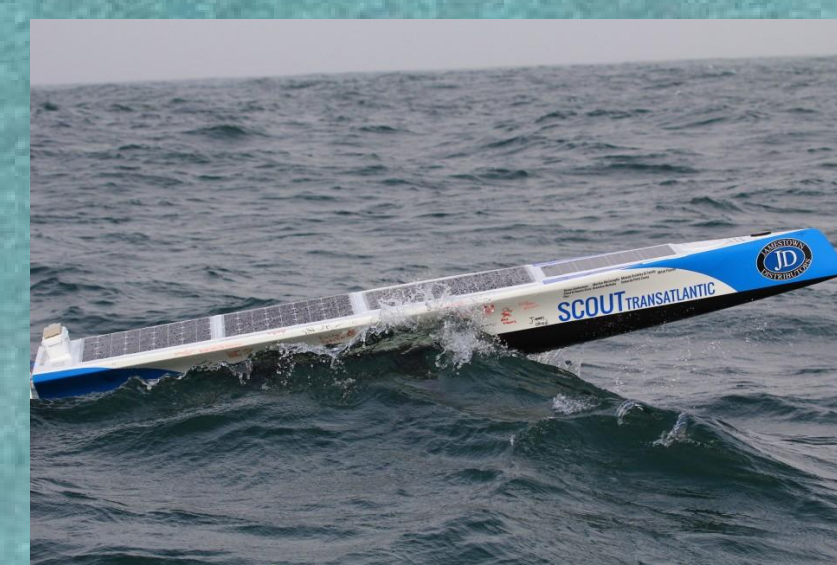

Above: The Scout Boat, which made it 1000 miles offshore and 3 months out on the sea before contact was lost.

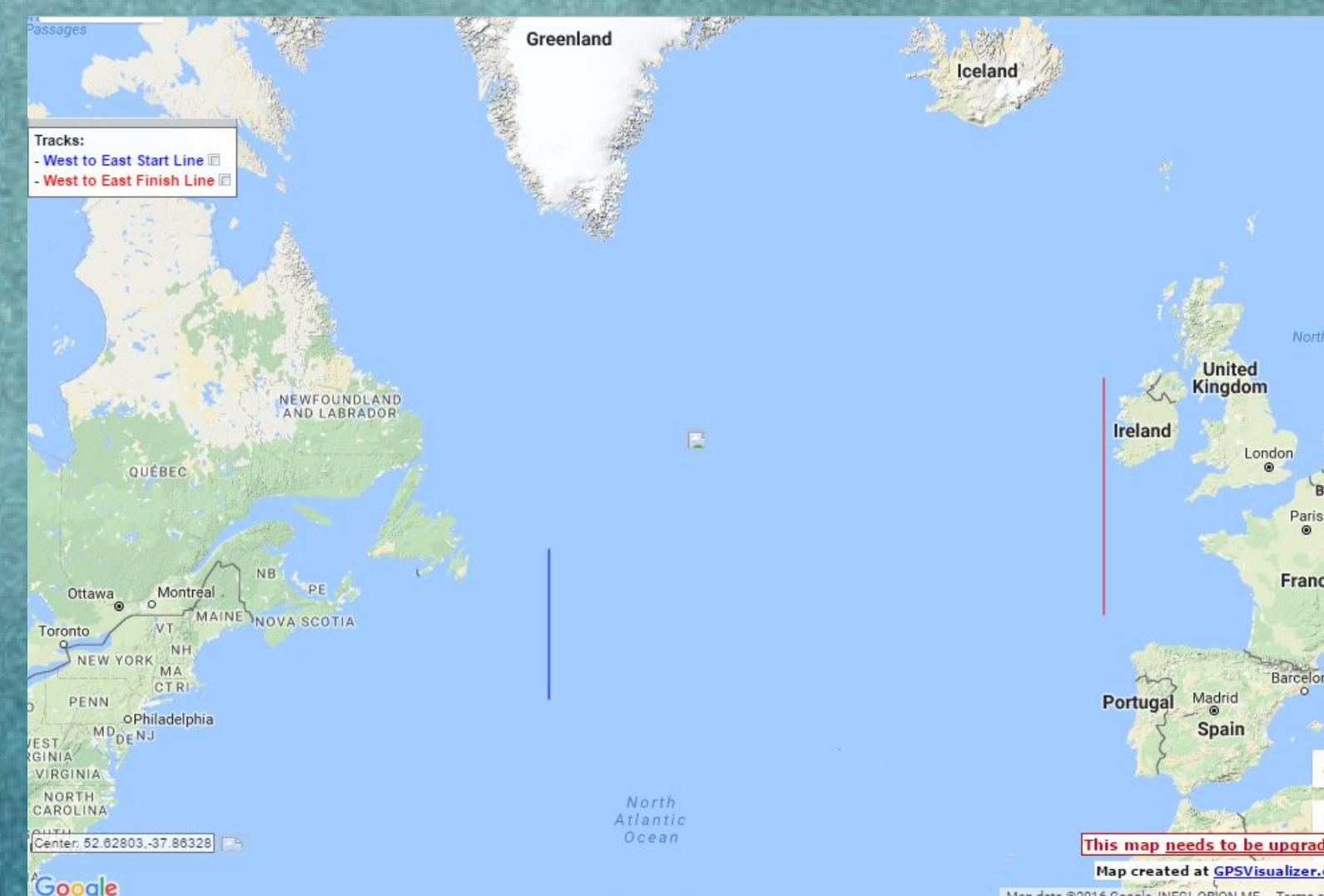

Right: start and finish lines.

TIMELINE

Progress Tracking	Start	Finish
WINTER QUARTER		
Installed engine into boat	week 1	week 4
Powertrain assembly	week 1	week 6
Rudder steering system	week 7	week 8
Propeller mount	week 7	week 8
SPRING QUARTER		
Program onboard systems	week 1	week 5
Test rudder action	week 3	week 5
Explore satellite comm	week 3	week 8
Construct roof assembly	week 6	week 9
Waterproof and test in sea	week 9	week 10

BUDGET

Academic Quarter	Available Funds
Fall	800
Winter	1800
Spring	800

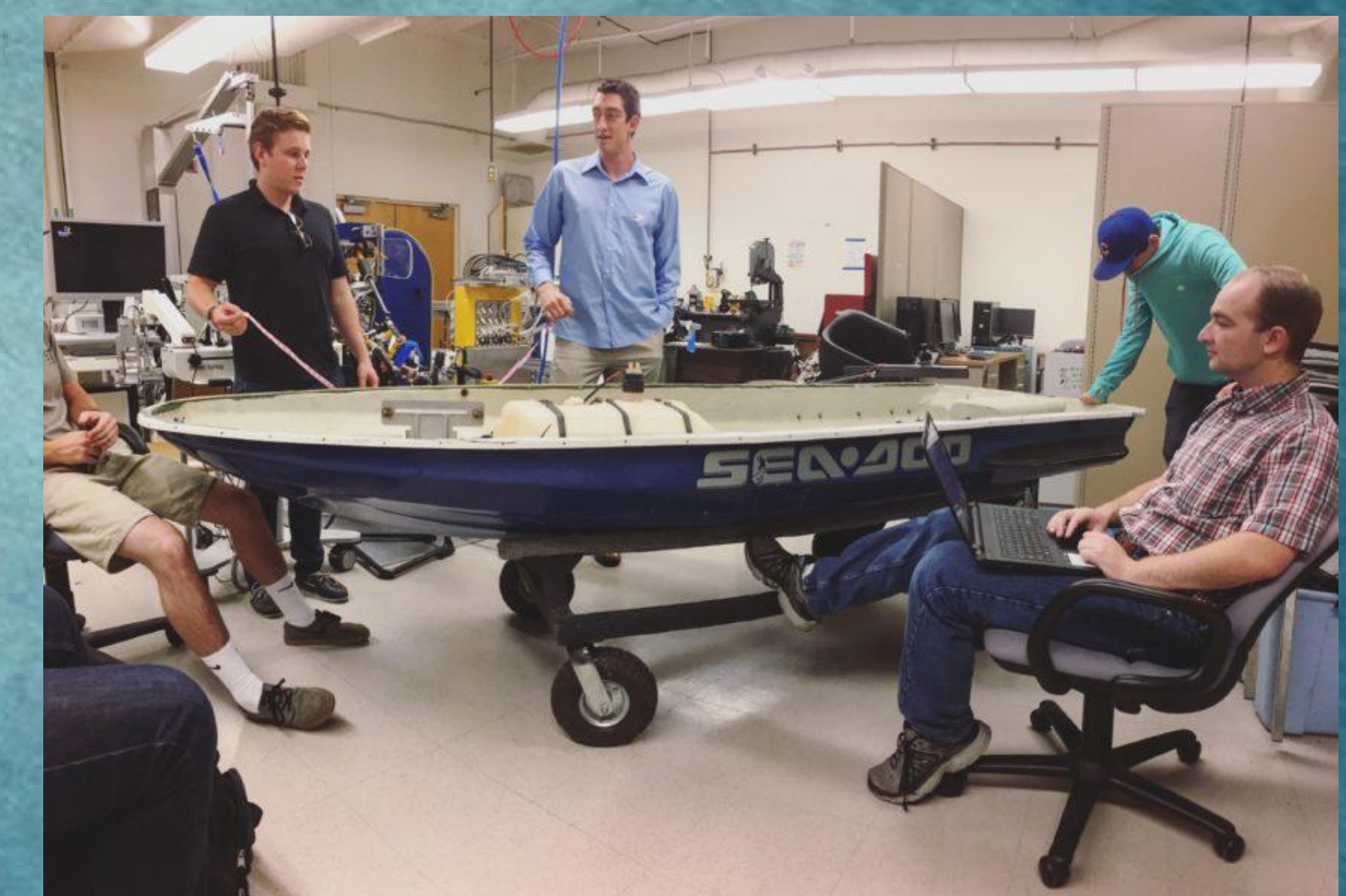

Team Members: Patrick Canler, Connor Kingman, Peter Phillips, Phillip Friedman, John Ellington, Jared Smith, Francisco Vega, Fabian Muresan, Nick Parks